

Main Features :-

Multi Voltage 24-240VAC/DC	Made in Spain
F05/F07 x 17mm ISO 5211	Stocked in UK
90Nm Break 85Nm run	Plug & Play Modulating kit
LED Status light	Plug & Play Failsafe kit
Manual override	Modulating Failsafe option
IP67 housing	Limit switches
Dome indicator	Anti Condensation Heater



TYPE: J3CS-85 Series

Dimensional Drawing:-

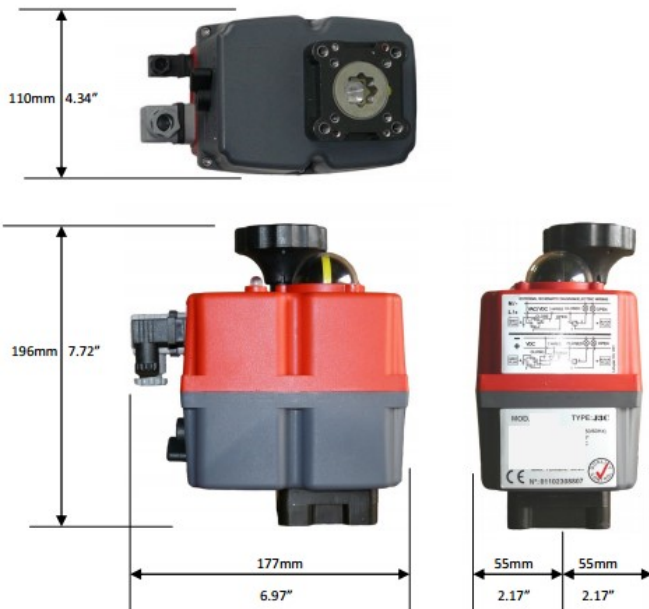

ISO5211 Mounting	F05	F07
Mounting PCD (mm)	50	70
Drive (Standard)	17mm	
Drive (Optional)	14mm or 14mm	

J3C S20 Materials of construction:	
Housing	Anti-corrosive Polyamide
Fasteners	Stainless steel
Gears	Polyamide (speed reducing) & steel (load bearing)
Shaft	Stainless steel
Output drive	Zamac
Position indicator	Clear Polyamide

Additional Technical Specification:-

Consumption

Supply Voltage	No load		At maximum operational torque 85Nm		At maximum break torque 90Nm	
	Amps	Watts	Amps	Watts	Amps	Watts
24V DC	0.33	7.90	0.88	21.20	0.90	21.20
48V DC	0.17	8.10	0.44	21.20	0.48	23.20
110V DC	0.05	5.80	0.13	14.80	0.15	16.50
24V AC	0.45	10.80	1.16	27.70	1.17	28.00
48V AC	0.28	13.30	0.28	33.10	0.71	34.10
110V AC	0.11	12.30	0.26	29.00	0.27	29.50
240V AC	0.08	18.50	0.16	38.00	0.16	

Note: To allow for inrush, and motor wear, MULTIPLY maximum consumption by 3 for sizing power supplies.

ISO 9001:2015 Accredited Company

Tel: +44(0)1386 552369

Fax: +44(0)1386 554227

sales@allvalves.co.uk

www.allvalves.co.uk

Allvalves Online Ltd, Automation House, Unit 2, Pershore, WR10 2DF UK

Dimensional Drawings and Additional Technical Specifications:-

J3CS ON - OFF ELECTRIC ACTUATOR

Power open, power close, stays put on loss of external power.

Options:

It is possible to change the J3CS actuator's function by installing user friendly plug and play function conversion kits. These will provide the following alternative functions:

Failsafe J3CS Actuator

J3CS fails to pre-set position using our BSR (Battery 'Spring Return' system which creates an alternate power supply should the external power fail.

Modulating J3CS Actuator

Movement of the J3CS actuator is proportional to an input control signal, typically 4-20mA or 0-10V, by installing our DPS (Digital Positioning System) user friendly plug and play kit. There are options for how the J3CS modulating reacts to loss of the control signal, but it will stay put on loss of external power.

Configuration options:

- 1) Closes on loss of control signal
- 2) Opens on loss of control signal
- 3) Stays put on loss of control signal

Failsafe Modulating J3CS Actuator

Failsafe modulating by installing the J+J BSR (Battery 'Spring Return') plug and play kit, operates functionally as a modulating electric actuator as described above, but will fail as per the DPS setting on loss of external power, as follows:

Configuration options:

- 1) Closes on loss of control signal, or on loss of power
- 2) Opens on loss of control signal, or on loss of power
- 3) Stays put on loss of control signal

Installing J+J Plug & Play function conversion kits

Failsafe and/or modulating function is quick and easy to achieve in the J3CS smart electric actuator by the fitting of the user friendly failsafe and/or modulating plug & play function conversion kits to the standard on-off J3CS smart valve actuator. When actuated valves are ordered with failsafe, modulating or failsafe modulating function, J+J install and test the plug and play function conversion kits. They can however be easily retro-fitted to J3CS smart electric actuators should the on-off function requirement (supplied as standard function), change.

Electrical Connection - Wiring of DIN Plugs

In J+J electric actuators all electrical connections are made externally using the external DIN plugs supplied with the actuator. There is no need to remove the valve actuator's cover to connect electrically. There are no terminals internally to connect to.

J3CS ON-OFF & FAILSAFE WIRING (Same connection for either)

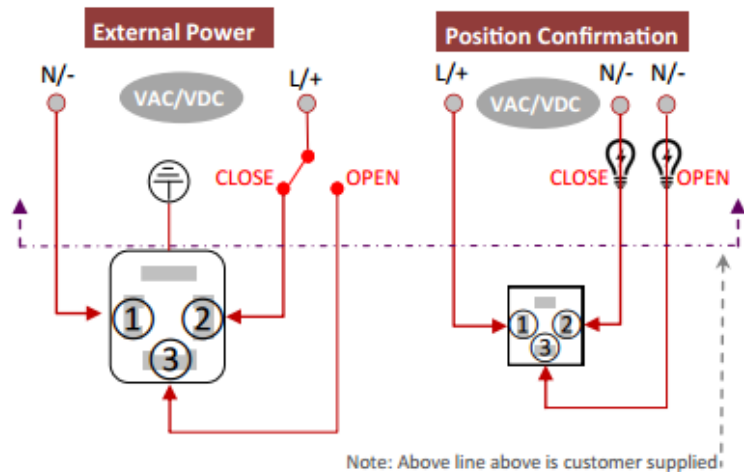

Optional Plug & Play Function Conversion Kits



Dimensional Drawings and Additional Technical Specifications:-

J3CS Multi-colour LED status light:

Actuator operational status	LED Colour
No power being supplied	Off ☼
Power being supplied to actuator	Fully OPEN = Solid ● Fully CLOSED = Solid ●
Actuator moving between open and closed	Open to close = flash ☼ ☼ ☼ ☼ Close to open = flash ☼ ☼ ☼ ☼
Actuator in MANUAL mode	Flash ☼ ☼ ☼ ☼ ☼ ☼
Torque limiter activated	If closing when activated = flash ☼ ☼ ☼ ☼ if opening = flash ☼ ☼ ☼ ☼
BSR failsafe system activated (for max 3 mins)	If configured Fail Close = flash ☼ ☼ ☼ ☼ if Fail Open = flash ☼ ☼ ☼ ☼
BSR Battery needs charging warning	Flash ☼ ☼ ☼ ☼ ☼ ☼ ☼ ☼ ☼ ☼
Actuator with DPS(2015) positioner	Opening = flash ☼ ☼ ☼ ☼ Closing = flash ☼ ☼ ☼ ☼ Stationary = ●

J3CS BSR Failsafe System Specifications:

Detail	J3C-S20
Initial charge time BEFORE being placed into operational service	28 Hours
Maximum movements with fully charged battery	5
Minimum recharge time after each movement	8 mins
Battery consumption when power drawn from battery	6.2W
Nominal battery capacity	1000mA
Current drawn when operating by battery	2.4mA
Charge consumption	36mA/h
System to change between fail close & fail open	PCB jumper

J3CS DPS:2015 Digital Positioner Specifications:

Detail	J3C-S Series
Input/ Output options	0-10V, 1-10V, 0-20mA, 4-20mA
Output shaft feedback system	Magnetic, digital
Accuracy, linearity, hysteresis, repeatability	Better than 2%

Dimensional Drawings and Additional Technical Specifications:-

J3C-S85 Electric Actuator Specifications

Voltage range - automatic sensing	24V - 220V AC (1ph) or DC
Operating time (0-90° no load)	29 seconds
Maximum break torque	90 Nm (796 lb.ins)
Maximum operating torque (run/ reseal)	85 Nm (752 lb.ins)
Duty rating	75%
IP Rating (IEC 60529)	IP67
Working angle Standard (on request)	90° (180° or 270° options)
Mounting ISO:5211 x DIN 3337	F05 & F07 x 17 (standard) 11 or 14mm drive output (Option)
Motor switches	2 x SPDT micro switches
End of travel confirmation (volt free)	2 x SPDT micro switches
Heater	3.5 W
Ambient temperature range	-20° to +70°C (-4 to +158°F)
Electrical connecting plugs	EN175301-803
Weight	3 kg
J3C-S85 Consumption	
Figures	See last page
Motor	24VDC 1ph, Class B, S4 service.

How this J3C electric 1/4 turn valve actuator works (on-off)

Electrically operated valves are driven by an electric actuator containing a motor and gearbox. On receipt of a continuous voltage signal (not pulse) the motor runs and, via a gearbox in the electric actuator, rotates the valve stem. The motor stops at the desired position (usually 0° or 90°) by an internal cam striking a micro-switch. The valve actuator remains in this position, with the voltage still applied continuously, until switched and a continuous voltage reversing signal (not pulse) is applied, which runs the motor in the opposite direction, reversing the rotation until a separate internal cam strikes a separate micro-switch and stop the motor.

J3C Main features

IP67 Weatherproof, UV protected, corrosion resistant plastic housing.

LED light gives user continuous visual actuator status feedback - if the LED is flashing, there's a problem!

Many protective features as standard - such as over-torque and anti-condensation.

Multi-voltage capable, automatically sensed

Very user friendly and easy to install - all the electrical connections are external.

Unique plug & play function conversion kits create FAILSAFE & MODULATING function from a standard on-off electric actuator.

Digital potentiometer feedback option

TYPE: J3CS-85 Series